

STANDARD INFORMATION

Standard Number: UL 817

Standard Name: Standard for Cord Sets and Power-Supply Cords

Standard Edition and Issue Date: 12th Edition Dated March 11, 2015

Date of Revision: March 11, 2015 and January 5, 2016

Date of Previous Revision of Standard: 11th Edition Dated July 24, 2014

EFFECTIVE DATE OF NEW/REVISED REQUIREMENTS

Effective Date: **February 7, 2021**

IMPACT, OVERVIEW, AND ACTION REQUIRED

Impact Statement: A review of all Listing Reports is necessary to determine which products comply with new/revised requirements and which products will require re-evaluation. **NOTE:** Effective immediately, this revised standard will be exclusively used for evaluation of new products unless the Applicant requests in writing that current requirements be used along with their understanding that their listings will be withdrawn on Effective Date noted above, unless the product is found to comply with new/revised requirements.

Overview of Changes:

The following changes reflect the March 11, 2015 12th edition release

- Several substantive changes were added in the 12th edition of UL 817.

The following changes reflect the January 5, 2016 revision

- Addition of requirements for rotating plugs.
- Addition of requirements related to overcurrent protection on 18 and 17 AWG extension cord sets.
- Addition of requirements to cover a construction of a general-use cord set employing a joint.

Specific details of new/revised requirements are found in table below.

If the applicable requirements noted in the table are not described in your report(s), these requirements will need to be confirmed as met and added to your report(s) such as markings, instructions, test results, etc. (as required).

Client Action Required:

Information – To assist our Engineer with review of your Listing Reports, please submit technical information in response to the new/revised paragraphs noted in the attached or explain why these new/revised requirements do not apply to your product (s).



Current Listings Not Active? – Please immediately identify any current Listing Reports or products that are no longer active and should be removed from our records. We will do this at no charge as long as Intertek is notified in writing prior to the review of your reports.

STANDARD INFORMATION

CLAUSE	VERDICT	COMMENT
		Additions to existing requirements are <u>underlined</u> and deletions are shown lined out below.
THE FOLLOWING CHANGES REFLECT THE MARCH 11, 2015 12TH EDITON RELEASE		
6	Info	Fittings – General
		<i>New section added;</i>
6.3		Accessibility of live parts
6.3.1		The electrical parts of a cord set or a power-supply cord that do not require use of a tool for access shall be located or enclosed so that persons are protected against inadvertent contact with uninsulated live parts and film-coated magnet wire.
6.3.2		The probe shown in Figure 6.1 shall not be able to contact uninsulated live parts of the connector. The probe shall be applied to any depth that the opening permits, and shall be rotated or angled before, during, and after insertion through the opening to any position that is required to examine the enclosure. The probe shall be applied in any possible configuration; and, when required, the configuration may be changed after insertion through the opening.
Figure 6.1		Articulate probe with web stop

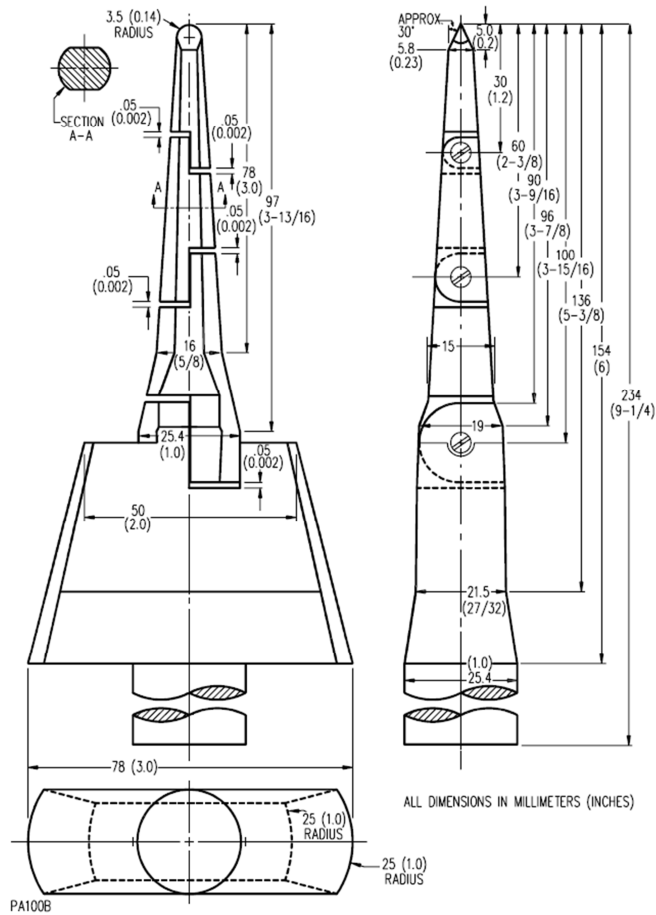

6.3.3	The probe shall be used as a measuring instrument to evaluate the accessibility provided by an opening and not as an instrument to evaluate the strength of a material; it shall be applied with the minimum force required to determine accessibility.
6.5	Info Identification and wiring
6.5.6	Flexible cord containing a grounding conductor shall not be assembled to a <u>non-grounding plug</u> or a <u>non-grounding connector</u> . a) To a 30-A, 3-pole, 3-wire, 125/250-V fitting with a 10-30R contact configuration, or b) To a 50-A, 3-pole, 3-wire, 125/250-V fitting with a 10-50R contact configuration.
6.7	New section added; Outdoor-use fittings



6.7.1		<p>Except as noted in 6.7.2, materials used for outdoor fittings when molded of polymeric material shall be subjected to:</p> <p>a) The Weather (sunlight) resistance test in the Standard for Polymeric Materials – Use in Electrical Equipment Evaluations, UL 746C for 720 h for carbon arc or 1000 h for Xenon-arc; and</p> <p>b) The Crushing and Impact Resistance tests as indicated in 11.7 and 11.8, respectively.</p>
6.7.2		Fittings molded of solid butyl rubber, neoprene, thermoplastic elastomer, or polyvinyl chloride shall not be required to comply with 6.7.1.
6.7.3		<p>A molded fitting attachment plug of butyl rubber, neoprene, or polyvinyl chloride is acceptable if in compliance with the Adhesion test, 11.11. Molded-on cord connectors of other materials are acceptable if determined so by the results of special investigation.</p> <p>Note: Special forms of construction not specified in this standard shall be subject to special investigation.</p>
7	Info	Plugs
7.3	Info	Hospital grade attachment plugs
7.3.1		<p>Hospital grade molded-on attachment plug shall comply with the requirements in 7.3 and Section 18, Hospital Grade Molded-On Plugs and Connectors, and with all other applicable requirements in this standard. <u>These requirements are applicable only to configurations 5-15P, 5-20P, 6-15P, and 6-20P in accordance with ANSI/NEMA WD 6. Attachment plugs shall be of the straight type (longitudinal axis of flexible cord parallel to that of the line blades), or right-angle type (longitudinal axis of flexible cord at right angle to that of the line blades), molded onto flexible cord.</u></p>
8	Info	Cord Connectors
8.6		Hospital grade connectors
8.6.1		<p>A hospital grade molded-on connector shall comply with the requirements in Section 18 and with all other applicable requirements in this standard. <u>These requirements are applicable only to configurations 5-15R, 5-20R, 6-15R, and 6-20R in accordance with ANSI/NEMA WD 6. Connectors shall be of the straight type (longitudinal axis of flexible cord parallel to that of the contacts), or right-angle type (longitudinal axis of flexible cord at right angle to that of the contacts), molded onto flexible cord.</u></p>
9	Info	Other Components
9.2	Info	Metal strain relief clamps
9.2.3		<p><i>New clause added;</i></p> <p>A strain relief clamp for Type SPT-3 shall comply with the test in 11.3.3 if the design of the clamp appears to cause damage to the cord.</p>



		<i>New section added;</i>
9.8		Supplementary circuit
9.8.1		A supplementary charging circuit provided in a general-use cord set or power-supply cord shall comply with the requirements of the Standard for Class 2 Power Units, UL 1310.
		<i>New section added;</i>
9.9		Devices employing remote control features
9.9.1		In addition to the requirements of this standard, general-use cord sets and special-use nondetachable power-supply cords employing remote control features shall comply with the Standard for Solid-State Controls for Appliances, UL 244A. Compliance with the Standard for Automatic Electrical Controls for Household and Similar Use, Part 1: General Requirements, UL 60730-1, and/or the applicable Part 2 standard from the UL 60730 series fulfills these requirements.
9.9.2		The electrical tungsten rating of the switching device shall be greater than or equal to the rating of the cord set or power-supply cord.
9.9.3		The switching device shall be capable of controlling up to and including a 1/2 HP motor. If the cord set or special-use power-supply cord is not intended for use with a motor load, the unit shall be marked as noted in 21.4.1 or 10.9.6.4, respectively.
9.9.4		The output shall not only be controlled by the remote controller. A separate individual switch/interface shall be provided on the unit to disconnect the main power of the device.
9.9.5		A switch used to directly control a load fitting, shall comply with the performance requirements contained in the Standard for General-Use Snap Switches, UL 20, for an AC only through cord switch or a special-use switch that complies with the Standard for Special-Use Switches, UL 1054, or the Standard for Switches for Appliances – Part 1: General Requirements, UL 61058-1. The switch shall be AC tungsten rated and have an electrical rating equal to or greater than the rating of the cord set or power-supply cord. These requirements apply to all switching mechanisms such as relays, supplementary protectors, and switches which contain symbols, words, or letters meaning ON/OFF.
9.9.6		A general-use cord set employing a remote control feature shall be marked in accordance with 21.1.12 and 21.1.13.
9.9.7		A special-use nondetachable power supply cord employing a remote control feature shall be marked in accordance with 10.9.5.2 and 10.9.6.3.
9.10	Info	Overcurrent protection
		<i>New clause added;</i>
9.10.5		The overcurrent protective device shall provide protection for each unidentified circuit conductor, but not for any identified (grounded) circuit conductor or grounding conductor unless all branch circuit conductors are simultaneously open. The overcurrent protective device shall not open the grounding conductor.
10	Info	Assembly



10.1	Info	Power-supply cords
		<i>New clause added;</i>
10.1.1.1		A power-supply cord shall be constructed with a flexible cord as defined in Table 10.1, a male plug at one end and non-terminated leads on the opposite end.
10.3	Info	Recreational vehicle power-supply cords
		The length of each power-supply cord for recreational vehicles shall not be less than 30 ft (9.1 m) when measured from the end of the line fitting to the cut end of the bared leads. See 6.5 and Figure 6.1.
10.3.1.1		Exception: The minimum length for power-supply cords intended for shipment to an OEM is 23.5 ft (7.16 m).
		<u>The minimum cord-exposed length for power-supply cords for recreational vehicles shall be:</u> <u>a) 7.5 m (25 ft) if intended for side entry; or</u> <u>b) 9 m (30 ft) if intended for rear entry.</u>
		<i>New clause added;</i>
10.3.1.2		Overall length shall be augmented by the difference between the height of the entry point on the recreational vehicle and 0.9 m (3 ft), if the intended entry point is above 0.9 m (3 ft).
10.6	Info	Range and dryer power-supply cord kits
		<i>New clause added;</i>
10.6.1.1		A power-supply cord kit shall consist of a suitable power-supply cord, a strain relief clamp or molded-on strain relief, reducing washers when required for proper installation, and assembly instructions.
10.7	Info	Extension cord sets
10.7.1	Info	Construction – Outdoor-use assemblies
		<i>New clause added;</i>
10.7.1.3		An outdoor-use cord set employing a 14 AWG flexible cord with 4 – 6 cord connectors shall employ an over current protective device and shall comply with the applicable requirements in 9.7, 9.10 and Section 17, Tests for Overcurrent Protective Devices. The rating of the over current device shall be equal to the rating of the cord set.
10.7.2	Info	Fittings (indoor and outdoor)
		<i>New clause added;</i>
10.7.2.1.1		Fittings shall comply with the construction requirements in Sections 6 – 8.



		<i>New clause added;</i>
10.7.2.1.2		Assemblies designated for outdoor use shall employ attachment plugs and cord connectors designated for outdoor use.
		<i>New clause added;</i>
10.7.2.1.3		The attachment plug and cord connector in an assembly shall be of the same mating configuration.
		<i>New clause added;</i>
10.7.2.1.4		An assembled-on or molded-on extension cord set shall employ an attachment plug and cord connector having one of the following configurations: 1-15, 5-15, 5-20, 5-30, 6-15, 6-20, 6-30, L1-15, L5-15, L5-20, L5-30, L6-15, L6-20, or L6-30.
		<i>New clause added;</i>
10.7.2.1.14		A general-use cord set employing in-line cord connectors shall employ SJ or equivalent cords.
10.7.2.2	Info	Joints for use on outdoor use cord sets
		<i>New clause added;</i>
10.7.2.2.6		The overall length of a cord set with a joint shall be determined from the sum of the lengths of the main cord (from plug to joint) plus the longest length of flexible cord from the joint to the cord connector.
		<i>New section added;</i>
10.7.2.3		Cold-usage cord sets
10.7.2.3.1		A cold-usage cord set shall consist of a grounded attachment plug, flexible cord rated for at least -50°C in accordance with the requirements of the Standard for Flexible Cords and Cables, UL 62, and a cord connector, in accordance with 8.5.6.
10.7.2.3.2		A cold-usage cord set shall comply with the Low-temperature insertion test described in 14.9.5 in addition to other applicable tests.
10.7.2.3.3		A cold-usage cord set shall be marked in accordance with 22.8 in addition to other applicable markings.
10.7.4	Info	Flexible cord
10.7.4.1.1		Flexible cord shall be of one of the Types in Table 10.8 and the size of the conductors shall be either 16 AWG (1.31 mm ²), 14 AWG (2.08 mm ²), 12 AWG (3.31 mm ²), or 10 AWG (5.26 mm ²).
10.9	Info	Special-use cord sets
10.9.4	Info	Length



New clause added;

10.9.4.2 The length of a special-use cord set if constructed with a NEMA or non-NEMA plug and a parallel-type cord shall have a maximum length of 6.1 m (20 ft). If made with jacketed cord, the maximum length shall be 15.2 m (50 ft).

10.9.6 Info Markings

New clause added;

10.9.6.1 Special-use cord sets shall comply with Section 31, Special Use Cord Sets.

New clause added;

10.9.6.2 Special-use cord sets using a single outlet having 1-15R configuration shall be marked in accordance with 32.4.

New clause added;

10.9.6.3 A special-use nondetachable power-supply cord employing a remote control feature shall be marked, "WARNING:" and the following or the equivalent, "The special-use cord set could turn on unexpectedly without the user being present. To Reduce the Hazardous Condition – Unplug the appliance that is plugged into the receptacle(s) of the device before servicing." Lettering shall not be less than 3/32 inch (2.4 mm) high and shall either be molded or hot stamped on the remote control device with letters not less than 1/20 inch (1.3 mm) high so as to be visible during use, or be provided on a permanent tag attached to the flexible cord. The leading edge of the tag shall be located within 3 inches (76.2 mm) of the point where the cord enters the body of the remote control device. The tag shall be attached in a manner that it cannot be easily removed. The tag shall have the added marking in letters not less than 3/32 inch (2.4 mm) high: "Do not remove this tag."

New clause added;

10.9.6.4 A special-use nondetachable power supply cord not intended for use with a motor load shall be marked, "WARNING:" and the following or the equivalent, "This special-use power supply cord is not to be used with a motor load." Lettering shall not be less than 3/32 inch (2.4 mm) high and shall either be molded or hot stamped on the remote control device with letters not less than 1/20 inch (1.3 mm) high so as to be visible during use, or be provided on a permanent tag attached to the flexible cord. The leading edge of the tag shall be located within 3 inches (76.2 mm) of the point where the cord enters the body of the remote control device. The tag shall be attached in a manner that it cannot be easily removed. The tag shall have the added marking in letters not less than 3/32 inch (2.4 mm) high: "Do not remove this tag."

10.11 Info **Recreational vehicle cord sets**



10.11.4		<p>The cord connector shall be of a 2-pole, 3-wire, 4-wire locking-type, L5-15, L5-20, L5-30, L5-50, L5-60, L6-15, L6-20, L6-30, L6-50, L6-60, L7-15, L7-20, L7-30, L7-50, L7-60, L8-20, L8-30, L8-50, L8-60, L9-20, L9-30, L9-50, L9-60, or L14-20, L14-30, L14-50, L14-60 configuration identical in ratings to the attachment plug attached to the supply end of the cord set. The cord connector shall be molded of butyl rubber, neoprene, or polyvinyl chloride (or other equivalent materials) and shall be molded to the flexible cord so that it adheres tightly to the jacket of the cord at the point at which the cord enters the connector body (see 11.11). <u>If a right-angle body is used, the configuration shall be oriented so that the grounding member is the member farthest from the point of cord entry.</u></p>
10.12	Info	<p>Hospital grade power-supply cords, extension cords, and cord sets</p>
		<p><i>New section added;</i></p>
10.12.2	Info	<p>Hospital grade extension cords</p>
10.12.2.1		<p>Hospital grade extension cords shall employ one of the plugs described in 7.3 and one of the connectors described in 8.6, and both fittings shall be of the same mating configuration.</p>
10.12.2.2		<p>The flexible cord employed shall be Type SJO, SJT, SJTO, or other jacketed type cord of equal or harder usage and either 16 AWG (1.31 mm²), 14 AWG (2.08 mm²), 12 AWG (3.31 mm²), or 10 AWG (5.26 mm²) size of conductors.</p>
10.12.2.3		<p>A hospital grade extension cord set shall have a maximum length of 4.6 m (15 ft).</p>
		<p><i>New section added;</i></p>
10.12.3		<p>Hospital grade cord sets</p>
10.12.3.1		<p>Hospital grade cord sets shall employ plugs described in 7.3 and connectors meeting the requirements of IEC 60320-1 or of another non-NEMA approved configuration.</p>
10.12.3.2		<p>A special use cord set incorporating design features not covered by this standard shall be evaluated with respect to the requirements for the specific application and any other items involved with its special use.</p>
11	Info	<p>Attachment plugs and cord connectors</p>
11.2	Info	<p>Security of insulation test</p>
		<p><i>New clause added;</i></p>
11.2.4		<p>If an insulation crimp connection is used, the conductor insulation shall be removed as close as possible to the insulation crimp. The pull shall then be applied between the bare conductor strands and the blade or contact.</p>
11.3	Info	<p>Strain relief test</p>



New clause added;

11.3.1.2 The test shall be performed by using dead weights or, at the manufacturer's option, a power-driven tensile testing machine. If a tensile testing machine is used, it shall have jaws suitable for holding the specimen and capable of applying the minimum required tensile load to the specimen while separating at a uniform rate not exceeding 25 mm/min. The machine shall be equipped with a scale from which the load can be read to a value of 0.4 N. The accuracy of the scale shall be within 2 percent of the value read, and weights shall be provided for calibrating the machine.

New section added;

11.3.7

Through-cord assemblies

11.3.7.1 No conductor of a through-cord assembly shall detach from a terminal of the fitting when subjected to a pull of 133 N (30 lbf), if the conductors are 18 AWG (0.824 mm²) or larger, and 89 N (20 lbf) if smaller than 18 AWG (0.824 mm²). A through-cord assembly shall be tested cord-to-cord. The pull shall be applied to the flexible cord in a direction perpendicular to the plane of the cord entry hole.

11.5

Info

Insulation resistance test

11.5.4

A quantity of ~~No. 7 lead steel~~ drop shot [approximate diameter 2.5 mm (0.10 in)] shall be placed in a container that is open at the top. After cord holes or other openings through which the shot can enter have been plugged carefully with a high-resistance insulating material, the fitting shall be immersed in the shot so that the shot serves as an electrode in contact with the surface to which the test is to be applied.

11.9

Info

Flexing test

New clause added;

11.9.5

The representative fitting shall be considered to comply with this test if the conductors have not opened after 2500 flexing cycles, as determined by a continuously-monitoring detection circuit.

12

Info

Tests for Attachment Plugs

12.1

Info

Security of blades and pins test

New clause added;

12.1.2

Each blade of a special use, miniature type attachment plug intended for use inside equipment, which is not accessible during normal servicing without the use of a tool, or provided with any means for retention of the blades in the mating female contacts, including provision for locking, shall be capable of withstanding a pull of 27 N (6 lbf) for 2 minutes without loosening.



New clause added;

12.1.3 The fitting shall be wired in the intended manner and then supported on a horizontal steel plate with the blades or pins, or both, projecting downward through a single hole just large enough to permit the blades or pins, or both, to pass through it. A weight that exerts the specified pulling force shall then be supported by each blade or pin in succession.

13 Info **Tests for Range and Dryer Power-Supply Cord Kits**

13.2 Info **Accelerated aging test**

New clause added;

13.2.1 An integral strain relief of rubber-like material shall show no signs of deterioration or cracks after being tested in accordance with 13.2.3.

New clause added;

13.2.2 An integral strain relief made of resilient plastic or synthetic elastomeric material shall show no cracks when flexed in accordance with 13.2.3, or other visible signs of deterioration resulting from exposure in a circulating air oven. The oven temperature and the duration of the test shall be in accordance with Table 13.2.

New table added;

Oven temperatures for aging test for range and dryer strain relief

Table 13.2

Temperature rating of material, °C	Duration of test days	Oven Temperature, °C
77	10	100 ±1
90	7	121 ±1
105	7	136 ±1

New clause added;

13.2.3 A flat section of a rubber specimen shall be exposed in a circulating air oven maintained at 100°C for a period of 70 h. The specimen shall then be cooled to room temperature and bent 90° around a mandrel having a diameter of approximately four times the thickness of the specimen at the point of bend.

14 Info **Tests for cord connectors**

New section added;

14.2

Conditioning cycles for blade retention test

14.2.1 Connector fittings shall be subjected to ten conditioning cycles of manual insertion and withdrawal of the standard test gauge described in the Standard for Attachment Plugs and Receptacles, UL 498. The force needed for the initial insertion of an attachment plug into a cord connector shall not exceed 180 N or 18.4 kgf (40.5 lbf).



New section added;

14.3

Retention of blades test

14.3.1

A connector fitting having a 1-15R, 5-15R, 5-20R, 6-15R, or 6-20R configuration shall be subjected to the retention of blades test described in 14.3.2 – 14.3.5.

14.3.2

Each of six devices shall be tested. The standard test gauge shall be configured as outlined in Table 14.1, except when testing a 1-15R, the grounding pin shall be removed. The gauge shall have the dimensions indicated in the test gauge figure in the Standard for Attachment Plugs and Receptacles, UL 498 but shall not have holes in the outer ends of the blades.

Test gauge configurations for conditioning

Table 14.1

Device under test	Test gauge	No. of devices tested
1-15R	1-15P	6
5-15R	5-15P	6
5-15R ^a	5-15P	3
	5-20P	3
6-15R	6-15P	6
6-20R ^a	6-15P	3
	6-20P	3

^a If the construction will accept both the 15 A and 20 A configurations, then 3 units of each shall be tested. If the construction will accept only 20 A configuration, then 6 units of each shall be tested.

14.3.3

The standard test gauge shall be configured as shown in Table 14.2 using the line blades without holes and with the grounding pin removed. The gauge shall then be inserted in the connector and a static 13 N (3 lbf) (including the weight of the gauge), which tends to remove the gauge from the connector, shall be applied for a period of 1 minute in a direction normal to the plane of the face of the connector. There shall not be more than 2 mm (0.08 in) displacement of the gauge. If the construction will accept both the 15-A and 20-A configurations, then 3 units of each shall be tested. If the construction will accept only the 20-A configuration, then 6 units of each shall be tested.

Test gauge configurations for retention testing

Table 14.2

Device under test	Test gauge	No. of devices tested
1-15R	1-15P	6
5-15R	1-15P	6
5-15R ^a	1-15P	3
	5-20P	3
6-15R	2-15P	6
6-20R ^a	2-15P	3
	2-20P	3

^a If the construction will accept both the 15 A and 20 A configurations, then 3 units of each shall be tested. If the construction will accept only 20 A configuration, then 6 units of each shall be tested.



14.3.4

The standard test gauge shall be configured as shown in Table 14.3 using the line blades with holes in the end and with the grounding pin in place. The 1-15R device shall be tested with the 1-15P test gauge without a grounding pin. The gauge shall then be inserted in the connector and a force applied in a direction normal to the plane of the face of the connector that tends to remove the gauge. The static force required to withdraw the gauge shall not exceed 67 N (15 lbf) (including the weight of the gauge).

Test gauge configurations for withdrawal testing

Tale 14.3

Device under test	Test gauge	No. of devices tested
1-15R	1-15P	6
5-15R	5-15P	6
5-15R ^a	5-15P	3
	5-20P	3
6-15R	6-15P	6
6-20R ^a	6-15P	3
	6-20P	3

^a If the construction will accept both the 15 A and 20 A configurations, then 3 units of each shall be tested. If the construction will accept only 20 A configuration, then 6 units of each shall be tested.

14.3.5

Each of the line contacts of the connector shall be tested using the test blade illustrated in Figure 14.1. Each line contact shall be capable of withstanding for 1 minute a static 2.2 N (0.5 lbf) applied to the test blade in a direction normal to the plane of the face of the specimen and in a direction that tends to remove the test blade, when the test blade is fully inserted in the contact opening. There shall not be more than 2 mm (0.08 in) displacement of the test blade.



Test blade

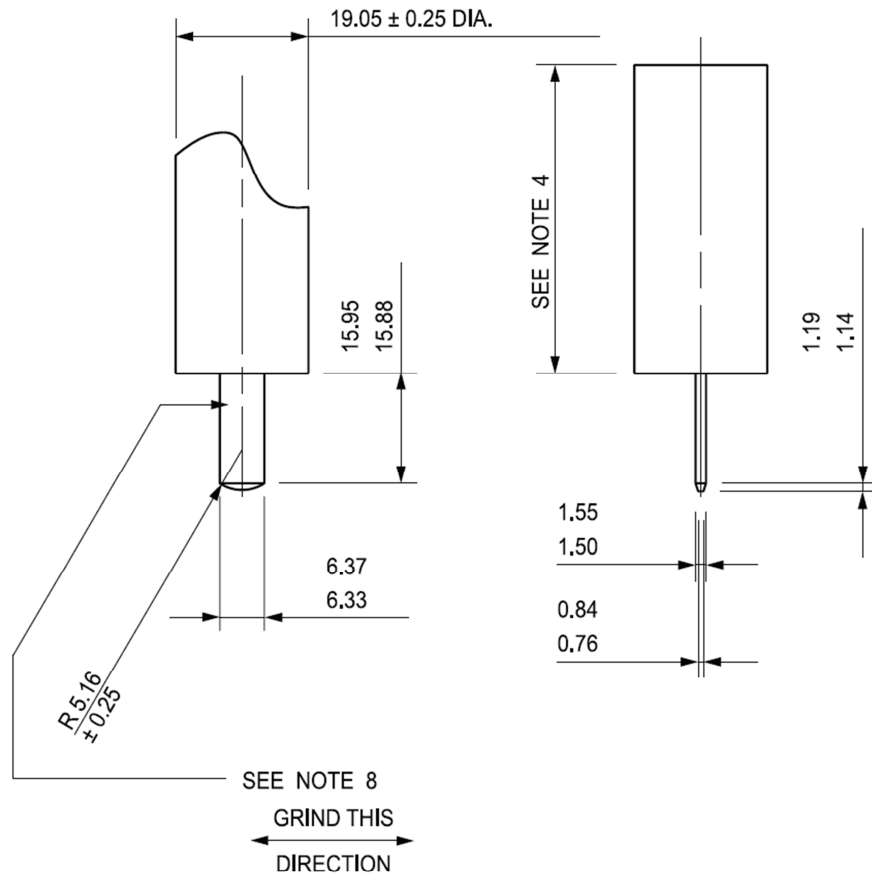

Figure 14.1

su1068

Notes:

1 – All dimensions in mm.

mm	0.25	0.76	0.84	1.14	1.19	1.50	1.55	5.16	6.33	6.37	15.88	15.95	19.05
(inch)	(0.010)	(0.030)	(0.033)	(0.045)	(0.047)	(0.059)	(0.061)	(0.203)	(0.249)	(0.251)	(0.625)	(0.628)	(0.750)

2 – Metric equivalents are based upon 1.00 inch = 25.4 mm.

3 – Axis of blade and axis on holder shall have a combined concentricity and axial alignment tolerance of 0.15 mm (0.006 inch) maximum T.I.R.

4 – Length to suit total tool weight of 0.50 pounds (2.2 N).

5 – The blade shall be fastened to the handle in a rigid manner.

6 – Sharp edges shall be removed to a maximum radius of 0.38 mm (0.015 in).

7 – The blade shall be of steel having a Rockwell Hardness of C58 to C60. The handle shall be cold rolled steel.

8 – The blade surfaces shall not exceed a 32 microinch finish grind in a direction perpendicular to the major axis. Finish shall be determined visually using a comparative method and 10X optical magnification.



14.5		NEW – Temperature test
14.6		NEW – Retention of blades test (repeated)
14.7		NEW – Resistance to arcing test
14.11		NEW – Closure of openings test
15		NEW – Tests for Flatiron and Appliance Plugs
16	Info	Test for Permanence of Warning Tag
16.1		NEW – Cords other than outdoor type
16.3		NEW – Oil-resistant cords
16.5		NEW – Evaluation
18	Info	Hospital Grade Molded-On Plugs and Connectors
18.3		NEW – Bonding (grounding) pin retention – hospital grade cord connector
18.4		NEW – Attachment plug connection and separation – hospital grade cord connector
18.5		NEW – Grounding contact temperature hospital grade cord connector
18.6		NEW – Ground resistance hospital grade cord connector
18.7		NEW – Crushing hospital grade attachment plug and cord connector
18.8		NEW – Impact hospital grade attachment plug and cord connector
18.9		NEW – Mechanical drop hospital grade attachment plug and cord connector
	Info	MARKING
20	Info	General
20.1		<p>Each cord set or power-supply cord, except as noted in 20.2, shall be marked where it will be plainly visible, as described in the requirements appropriate to the specific type of cord set or power-supply cord, with the following:</p> <p>a) The manufacturer’s name, trade name, or trademark or other descriptive marking by which the organization responsible for the product may be identified,</p> <p>b) The electrical rating in volts, amperes, and watts. The international symbol “~” for AC shall be used and “—” for DC. The symbol for amperes shall be “A”, for volts “V” and for watts “W”, and</p> <p>c) A distinctive fitting catalog number or the equivalent where practical.</p>
21	Info	Extension Cord Sets
21.2	Info	Polarization
21.2.1		<p><i>New clause added;</i></p> <p>Extension cord sets having 1-15 plug with a polarized configuration, shall be marked in a legible, distinct and prominent manner, in a color that contrasts with a solid color background, with the following marking: “CAUTION: This is a POLARIZED extension cord set. To prevent electric shock, match wide blade of plug to wide slot and insert. The polarized plug is not intended to be mated with nonpolarized outlets (having both slots the same size)”.</p>



THE FOLLOWING CHANGES REFLECT THE JANUARY 1, 2016 REVISION

10	Info	Assembly
10.7	Info	Extension cord sets
10.7.2	Info	Fittings (indoor and outdoor)
		<i>New section added;</i>
10.7.2.2A		Joints for use on extension cord sets
10.7.2.2A.1		An extension cord set with more than one single-outlet load fitting may have a joint in the flexible cord with the cord branching to two cords, each terminating in a single-outlet load fitting. See Fig 10.5 for typical construction.
10.7.2.2A.2		An extension cord set employing a joint shall employ SJ or equivalent cord.
10.7.2.2A.3		A joint between two flexible cords shall have a minimum insulating-body thickness of 3/32 inch (2.4 mm) covering all live parts.
10.7.2.2A.4		The thickness mentioned in 10.7.2.2A.9 is to be measured from any part of the live contacts and uninsulated flexible-cord conductors (conductors from which the flexible-cord insulation has been removed) to the nearest point on the outer surface of the insulating body.
10.7.2.2A.5		An extension cord set with more than one single-outlet load fitting may have a joint in the flexible cord and shall be marked in accordance with 21.1.11.
10.7.2.2A.6		An outdoor-use extension cord set may have a joint in the flexible cord with the cord branching to two cords, each terminating in a load fitting provided with a maximum of three outlets, or to three cords, each terminating in a load fitting provided with a maximum of two outlets. In either case, the total number of outlets provided on the cord set shall not be more than six.
10.7.2.2A.7		The resistance of the joint insulation to sunlight and mechanical abuse for outdoor use extension cord sets shall be at least equal to that of the interconnecting flexible cord. Molded-on joint insulation shall be compatible with the material used in the jacket of the flexible cord and shall adhere tightly to the jacket so as to exclude moisture.
10.7.2.2A.8		A joint between two flexible cords in an outdoor-use extension cord set shall have a minimum insulating-body thickness of 3/32 inch (2.4 mm) covering all live parts.
10.7.2.2A.9		The thickness mentioned in 10.7.2.2A.8 is to be measured from any part of the live contacts and uninsulated flexible-cord conductors (conductors from which the flexible-cord insulation has been removed) to the nearest point on the outer surface of the insulating body.
10.7.2.2A.10		Insulation of neoprene, polyvinyl chloride, or butyl rubber is acceptable provided its adhesion to the cord jacket complies with 11.11. Joint insulation of other material may be investigated to determine its acceptability.



10.7.2.2A.11 The overall length of a cord set with a joint shall be determined from the sum of the lengths of the main cord (from plug to joint) plus the longest length of flexible cord from the joint to the cord connector.

New supplement added;

Supplement
SD

ROTATING PLUGS

This supplement covers rotating attachment plugs that utilize slip rings within the body of the attachment plug (see standard for details).

CUSTOMERS PLEASE NOTE: This Table and column “Verdict” can be used in determining how your current or future production is or will be in compliance with new/revised requirements.
